

EXPLOSION, WITH PART LIST

250 GPH

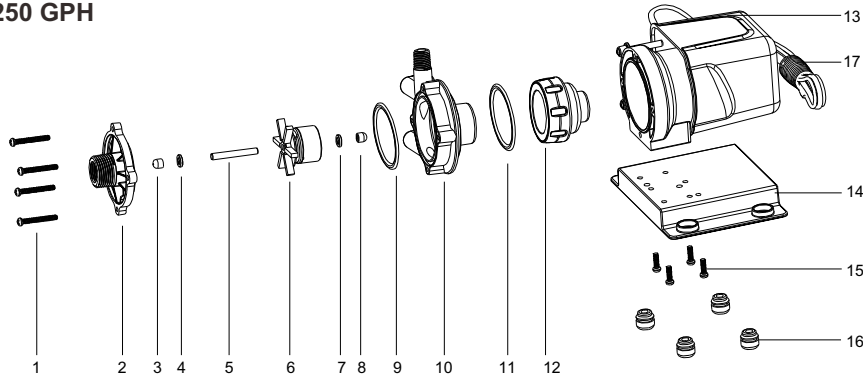

500 GPH

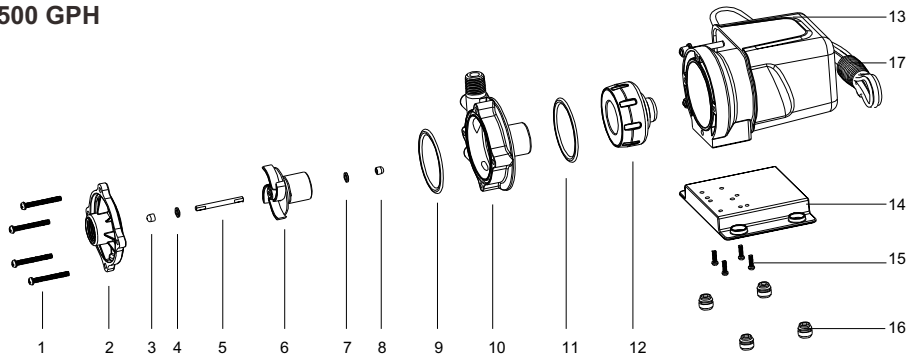

Key	Description	Composing Material	Quantity
1**	Screws	Stainless steel	4
2*	Pump cover	Nylon	1
3*, 8*	Rubber cap	EPDM	2
4*, 7*	Washer	Ceramic	2
5*	Shaft	Ceramic	1
6*	Impeller system	Nylon, Magnet, Graphite	1
9*, 11	O-ring	EPDM	2
10*	Pump chamber	Nylon	1
12	Drive magnet	Magnet, Aluminum, Nylon	1
13**	Motor housing	Nylon, Motor, Epoxy resin, Stainless steel	1
14**	Marine base	Nylon	1
15**	Screws	Stainless steel	4
16**	Mounting feet	Rubber	4
17**	Power cord	PVC	1

* Contacts solution inside the pump
 ** Contacts solution when submerged

SEAFLO®

AIR CONDITIONING PUMP

OWNER'S MANUAL

INTRODUCTION

Your SeaFlo marine air conditioning pump is made to circulate seawater through your marine air conditioning system. For any other uses besides salt, fresh, or sea water, please consult our chemical compatibility chart.

INSTALLATION

Mount the pump by screwing four 8 gauge (4 mm head diameter) screws through the mounting holes to secure the pump. The pump can be mounted vertically or horizontally. If mounted vertically, the pump head should be above the motor to prevent airlock.

OPERATION

Your SeaFlo marine air conditioning pump has a motor casing that is completely sealed from the outside. This means the pump can function while completely submersed or placed in a damp area, like a bilge. The pump is powered by a magnetic drive complex, so the motor is completely separated from the impeller water containing chamber.

The pump is a centrifugal pump, and, like all marine AC pumps, not self-priming.

The pump is safe to run dry, but, for optimal performance, please keep your pump primed so the water can lubricate the impeller and cool the motor. Your pump will not cool your AC system if it is running dry.

The pump can run continuously, when needed.

The pumps can operate on systems up to 12,000 BTU for the SFCPA1-G250-01 or 24,000 BTU for the SFCPA1-G500-01 at a head of 3 feet. According to your application, the pump may work differently for you. Ask your distributor if you have any questions. Please contact SEAFLO if you need any support.

We recommend an inlet strainer between 10-50 mesh. A strainer that is too large will not filter enough, and one too small will restrict flow.

Only operate at the voltage specified on the pump. Damage to the motor or damage to your boat may happen if incorrect input voltage is applied to the pump.

MAINTENANCE

The pump should be taken apart periodically for maintenance. To inspect your pump, unscrew the 4 head screws shown in the part explosion on page 4, and make sure nothing is blocking the impeller chamber and that the impeller is free to move. Clean the cooling tubes periodically by using either a weak acid cleaning solution, pressurized air, or water. Make sure to properly winterize the pump by emptying it of water and running antifreeze through the system.

To reassemble, slide the impeller on the shaft. Make sure it is facing the correct direction. Be sure that pump head components are aligned the same as pictured in the part explosion. Place the pump head back on and hand tighten the screws securely, but do not overtighten. Make sure the O-ring is located correctly and sealing the head.

Be sure to regularly clean your intake strainer.

WARRANTY

All SEAFLO products are backed by our 2 Year Warranty. For more information, please contact us.

TROUBLESHOOTING

No flow/reduced flow: Check that the pump is powered and running. Make sure the pump is below the waterline. Make sure there are no obstructions in the line. Make sure there are no air bubbles in your system. Your plumbing should have no downward bends in which air can accumulate.

Motor is hot: Make sure the cooling tubes in the pump are not obstructed. If you suspect a blockage, use water or air to remove any debris.

Leaks: Ensure that the screw holding on the pump head are tight. Ensure the O-ring sealing the pump head is correctly placed. Check for any cracks or holes. If so, a replacement may be necessary.

CHART 1: HEAD/FLOW

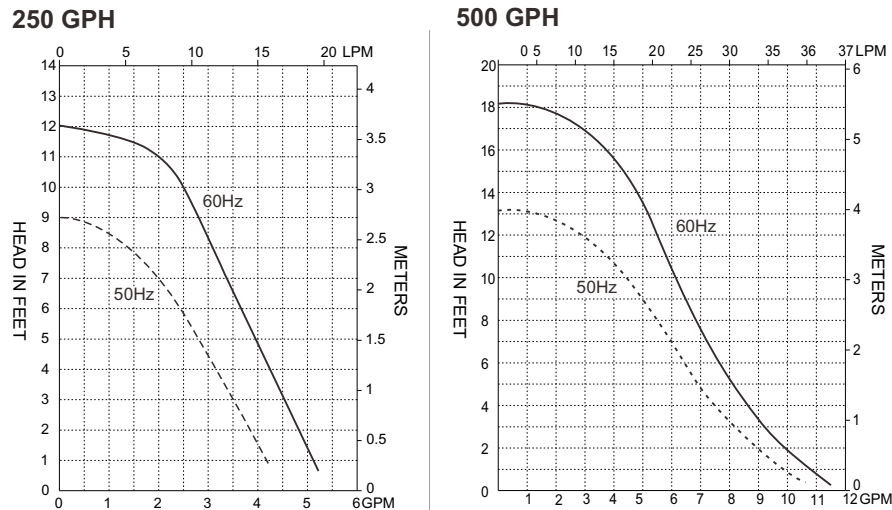

SPECIFICATIONS

250 GPH								
MODELS	SFCPA1-G250-01(115V)			SFCPA2-G250-01(230V)				
UNITS	60 Hz		50 Hz		60 Hz		50 Hz	
MAX FLOW	5.0 GPM		18.5 LPM		5.0 GPM		18.5 LPM	
MAX HEAD	13 ft / 5.7 psi		2.7 m		13 ft / 5.7 psi		2.7 m	
INLET	3/8" FPT or 3/4" MPT			3/8" FPT or 3/4" MPT				
OUTLET	1/4" MPT			1/4" MPT				
MAX INTERNAL PRESSURE	25 psi / 172 kPa			25 psi / 172 kPa				
MAX LIQUID TEMPERATURE	130 °F / 54 °C			130 °F / 54 °C				
ELECTRICAL 60 HZ	W	A	HP	RPM	W	A	HP	RPM
	56	0.99	1/35	3450	55	0.5	1/35	3450
ELECTRICAL 50 HZ	W	A	KW	RPM	W	A	KW	RPM
	56	1.1	0.021	2850	55	0.56	0.021	2850
UNIT SIZE	Height	Width	Length	Height	Width	Length	Height	Width
	4.92"	5.6"	6.26"	4.92"	5.6"	6.26"	4.92"	5.6"
	12.5 cm	14.2 cm	15.9 cm	12.5 cm	14.2 cm	15.9 cm	12.5 cm	14.2 cm
500 GPH								
MODELS	SFCPA1-G500-01(115V)			SFCPA2-G500-01(230V)				
UNITS	60 Hz		50 Hz		60 Hz		50 Hz	
MAX FLOW	8.5 GPM		31 LPM		8.5 GPM		31 LPM	
MAX HEAD	19 ft / 8.2 psi		4.3 m		19 ft / 8.2 psi		4.3 m	
INLET	3/4" FPT			3/4" FPT				
OUTLET	1/2" MPT			1/2" MPT				
MAX INTERNAL PRESSURE	25 psi / 172 kPa			25 psi / 172 kPa				
MAX LIQUID TEMPERATURE	130 °F / 54 °C			130 °F / 54 °C				
ELECTRICAL 60 HZ	W	A	HP	RPM	W	A	HP	RPM
	115	1.8	1/20	3450	110	0.9	1/20	3450
ELECTRICAL 50 HZ	W	A	KW	RPM	W	A	KW	RPM
	110	1.9	0.037	2850	105	0.9	0.037	2850
UNIT SIZE	Height	Width	Length	Height	Width	Length	Height	Width
	5.7"	5.6"	7.4"	5.7"	5.6"	7.4"	5.7"	5.6"
	14.45 cm	14.2 cm	18.8 cm	14.45 cm	14.2 cm	18.8 cm	14.45 cm	14.2 cm

Disclaimer: All specifications & data are based on pumping water and are intended as a guideline only. Specifications may vary.